

TECHNICAL DATA

FOZMULA
INNOVATION IN SENSORS

G/LL146 hydrostatic contents gauge



The **Model G/LL146** is an open hydrostatic gauge designed to continuously display the liquid level of a tank. Incorporating a remotely operated air pump, the **G/LL146** requires to be primed to ensure the accuracy of a reading.

Using a polyurethane capillary tube to measure the tank level, the gauge is supplied in liquid depth ranges as shown below:

SPECIFICATION

Construction

Body: Nylon 6
Window: Polycarbonate

Mounting:

Via a self centering locking spin ring
Gauge connector to tank via a 1/8" O.D. capillary tube
Panel cut-out: Ø53mm
Max panel thickness: 8mm

Other parameters

Accuracy: 5%
Max depth of tank: See table below

Fluid Types

Fluids compatible with Polyurethane

Environmental Ratings

Temperature: -20°C to +55°C
Sealing: IP54 from front of gauge only
Vibration: 20g @ 3300 rpm

Model	Min/Max tank depth - diesel	Min/Max tank depth - water
G/LL146/12	0 – 875mm	0 – 700mm
G/LL146/13	875 – 1850mm	700 – 1440mm

Note: The G/LL146 is not suitable for tanks less than 300mm deep.

Pump assembly

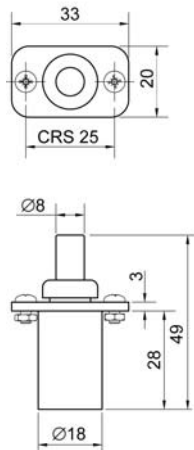

Gauge

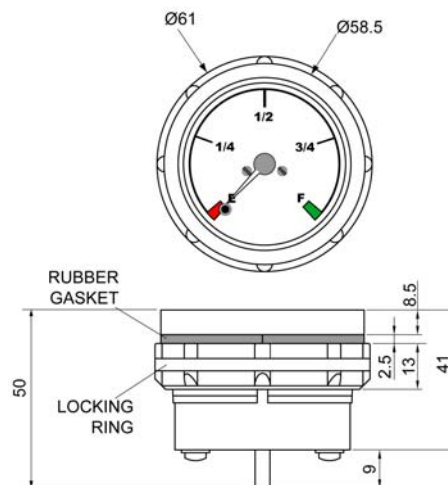

Berrington Road | Leamington Spa | Warwickshire CV31 1NB | UK

Tel: +44 (0)1926 466700 | Fax: +44 (0)1926 450473 | www.fozmula.com

www.fozmula.com

E. & O. E© Fozmula Limited. November 2008 Issue No. 1

Since the suitability of these products depends upon a wide range of factors not in our control, Fozmula Limited expects and understands that you will conduct the testing and evaluation necessary to determine that these products are suitable for your application. Whilst every effort is made to ensure the above details are correct at the time of printing, Fozmula Limited reserves the right to make material changes, and or technical changes without notification.