

TECHNICAL DATA

FOZMULA
INNOVATION IN SENSORS

G/LL148 – 100mm hydrostatic contents gauge



The **Model G/LL148** is a closed hydrostatic gauging system which works from a remote transmitter. The continuous reading gauge, sealed to IP67, is designed to be panel mounted, but a universal mounting adaptor is an optional extra. The transmitter, sited on the floor of a tank, is constructed to minimise the risk of debris and contains a pressure sensitive diaphragm. It is connected to the gauge via a copper capillary.

The system is manufactured in the four ranges of tank depths shown below:

SPECIFICATION

Gauge:

Construction

Nom diameter:	120mm
Face diameter:	95.7mm
Panel cut out:	Ø 75.5mm
Body material:	Aluminium
Window:	Polycarbonate

Other parameters

Sealing:	IP67 to front of gauge
Max depth of tank:	See table below
Max length of capillary:	10M (32 ft)
System priming:	Every 2 years or at the service interval of the tank

Transmitter:

Construction

Dimensions:	See drawing below
Body material:	Brass
Diaphragm:	Viton 70Q rubber
Weight:	250g (9 oz)

Fluid Types

Fluids compatible with polypropylene, copper, brass & Viton 70Q rubber

Environmental Ratings

Temp. ranges:	Fluid: -10°C to +40°C (+14°F to 104°F)
	Ambient: -10°C to +40°C (+14°F to 104°F)
	Transient: to +150°C (+300°F) for 4 hours max

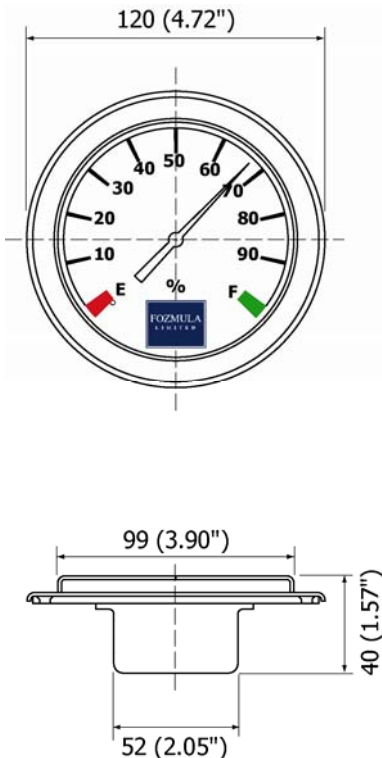

Model	Min/Max tank depth - diesel	Min/Max tank depth - water
G/LL148/06	0 – 750mm (0" to 30")	0 – 600mm (0" to 24")
G/LL148/07	751 – 1250mm (30" to 49")	601 – 1000mm (24" to 39")
G/LL148/08	1251 – 2500mm (49" to 98")	1001 – 2000mm (39" to 78")
G/LL148/09	2501 – 3750mm (98" to 148")	2001 – 3000mm (78" to 118")

Note: Minimum tank depths are 300mm (12") for water and 375mm (15") for diesel

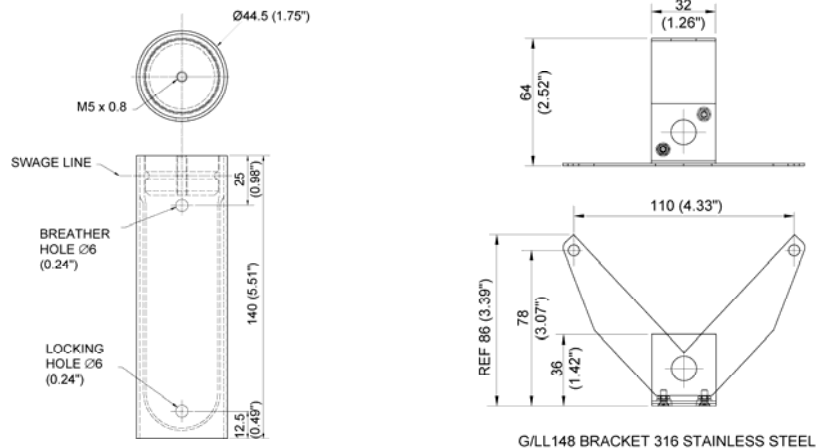

Berrington Road | Leamington Spa | Warwickshire CV31 1NB | UK

Tel: +44 (0)1926 466700 | Fax: +44 (0)1926 450473 | www.fozmula.com

www.fozmula.com

E. & O. E.© Fozmula Limited. November 2008 Issue No. 1

Since the suitability of these products depends upon a wide range of factors not in our control, Fozmula Limited expects and understands that you will conduct the testing and evaluation necessary to determine that these products are suitable for your application. Whilst every effort is made to ensure the above details are correct at the time of printing, Fozmula Limited reserves the right to make material changes, and or technical changes without notification.