

TECHNICAL DATA

FOZMULA
INNOVATION IN SENSORS

OP/01 tank overfill prevention probe



The **Model OP/01** tank overfill prevention probe is designed for use in static bulk storage fuel tanks and operates by passing a signal back to the fuel delivery system when the fuel reaches the maximum filling level.

The probe utilises a fast response glass encapsulated PTC thermistor to sense the presence of fuel. When the thermistor's resistance changes due to being immersed, further fuel delivery is prevented by the probe when it is interfaced to the hand held pump bypass controller.

The OP/01 complies fully with BS EN13616:2004 for overfill prevention devices.

SPECIFICATION

Construction:

Enclosure & stem: Polypropylene UV stabilised
Seals: Nitrile rubber

Electrical:

Connection: Plug Type 907
Thermistor response time: <1 sec

Fluid types:

Fluids compatible with polypropylene and nitrile rubber

Environmental:

Temperature - operating: +5°C to +30°C
- storage: -20°C to +60°C

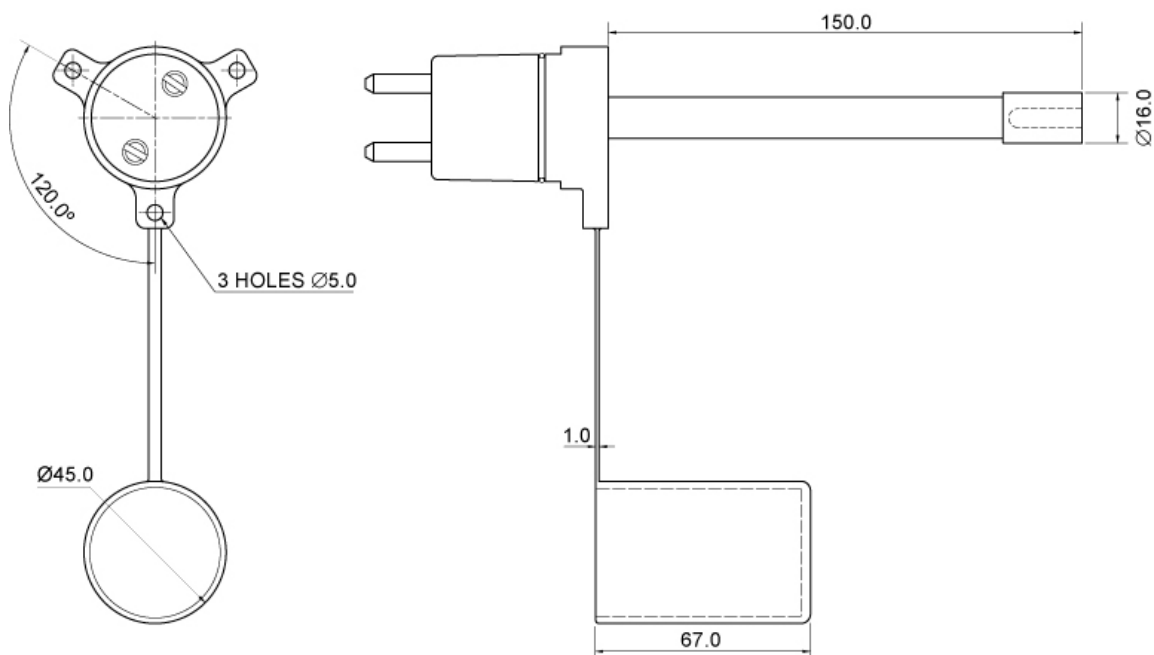

Berrington Road | Leamington Spa | Warwickshire CV31 1NB | UK

Tel: +44 (0)1926 466700 | Fax: +44 (0)1926 450473 | www.fozmula.com

www.fozmula.com

E. & O. E.© Fozmula Limited. February 2010 Issue No. 1

Since the suitability of these products depends upon a wide range of factors not in our control, Fozmula Limited expects and understands that you will conduct the testing and evaluation necessary to determine that these products are suitable for your application. Whilst every effort is made to ensure the above details are correct at the time of printing, Fozmula Limited reserves the right to make material changes, and or technical changes without notification.