

## TECHNICAL DATA

**FOZMULA**  
INNOVATION IN SENSORS

### Temperature switches and sensors



The **S30** series temperature switches and the **T/T** temperature sensors compliment our other engine monitoring equipment.

Using a curie point switching element the **S30** provides absolute repeatability, automatic re-setting, compact size, great reliability in use and long life. There are five standard thread sizes each with three temperature settings, but other thread or temperature combinations can be offered if volumes are sufficient. **T/T** sensors generally utilise a precision NTC or PTC thermistor and are custom designed to each application. Please ask for more information.

## SPECIFICATION

### S30 series

#### Construction:

**Body:** Brass  
**Standard thread sizes:** 1/2" NPTF, 3/8" BSPT, 1/2" BSPT and M18 x 1.5  
**Cap:** 15% Glass filled Nylon 6  
**Terminals:** 6.4mm spades, Earth or Isolated return.

#### Dimensions:

See below

#### Electrical:

**Switching:** 2.5A @ 250VAC  
**Contacts:** 1.6 A COS  $\phi$  = 0.6  
**Switching tolerance:**  $\pm 5^\circ\text{C}$   
**Switching differential:**  $10^\circ\text{C}$

#### Temperature:

**Full range:**  $+50^\circ\text{C}/+ 150^\circ\text{C}$  in  $10^\circ\text{C}$  increments - subject to minimum quantity  
**Standard products:**  $90^\circ\text{C}$ ,  $100^\circ\text{C}$ ,  $105^\circ\text{C} \pm 5^\circ\text{C}$

### T/T series

Manufactured using thermistors and custom housings to suit each application.

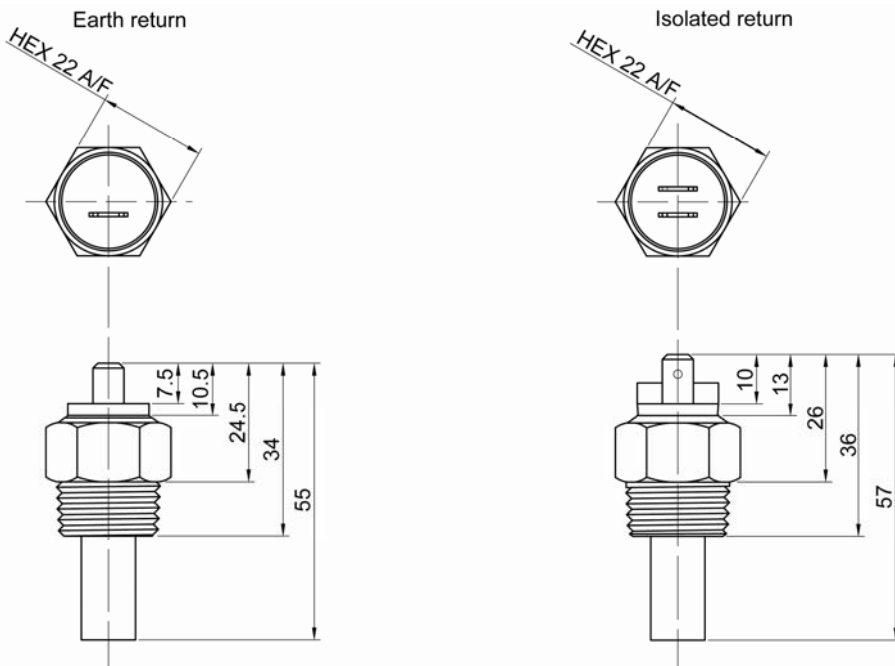

Berrington Road | Leamington Spa | Warwickshire CV31 1NB | UK

Tel: +44 (0)1926 466700 | Fax: +44 (0)1926 450473 | [www.fozmula.com](http://www.fozmula.com)

[www.fozmula.com](http://www.fozmula.com)

E. & O. E.© Fozmula Limited. December 2003 Issue No. 1

Since the suitability of these products depends upon a wide range of factors not in our control, Fozmula Limited expects and understands that you will conduct the testing and evaluation necessary to determine that these products are suitable for your application. Whilst every effort is made to ensure the above details are correct at the time of printing, Fozmula Limited reserves the right to make material changes, and or technical changes without notification.