

TECHNICAL DATA



T/LL130 series liquid level sensor



The **Model T/LL130** series is designed for use in water, coolant or fuel/oil tanks and provides a variable resistive, voltage or PWM (Pulse Width Modulated) output suitable for driving industry standard fuel gauges or connecting into PLCs.

The device has no moving parts and can be mounted at any angle as long as it covers the whole depth of the tank. An optional manual calibration feature is available.

SPECIFICATION

Dimensions:

Probe length: Min 200mm, Max 2000mm (Min 8", Max 78")

Electrical:

Supply voltage: 7-35Vdc*
Warning output: Switch to ground. Max 100mA
Connections: 4 way Delphi Packard connector (Metri-Pak 150 series)

*Protected against overvoltage (80Vdc for 2 minutes) and incorrect electrical connection

Supply current: 15 – 30mA
Output signal: Factory set values between 0-250Ω or 250-0Ω, or between 0-5V or 5-0V
Linearity: 1%
Accuracy: ±2% of depth @ 20°C (+68°F)

Construction:

Housing: 30% glass filled Nylon 6
Sensor tube: Stainless steel 316

Internal sensor: PTFE covered stainless steel
Seals: NBR rubber

Fluid Types:

Fluids compatible with 316 St/St, Nylon 6, PTFE & Nitrile rubber. N. B. Not suitable for fuels which contain Toluene.

Environmental Ratings:

Temperature - operating: -40°C to +85°C (-40°F to +185°F)
- storage: -55°C to +100°C (-67°F to +212°F)
Vibration: BS EN 60068-2-64:1993 (15.3grms)

Sealing: IP67
Shock: 50g 6.3ms

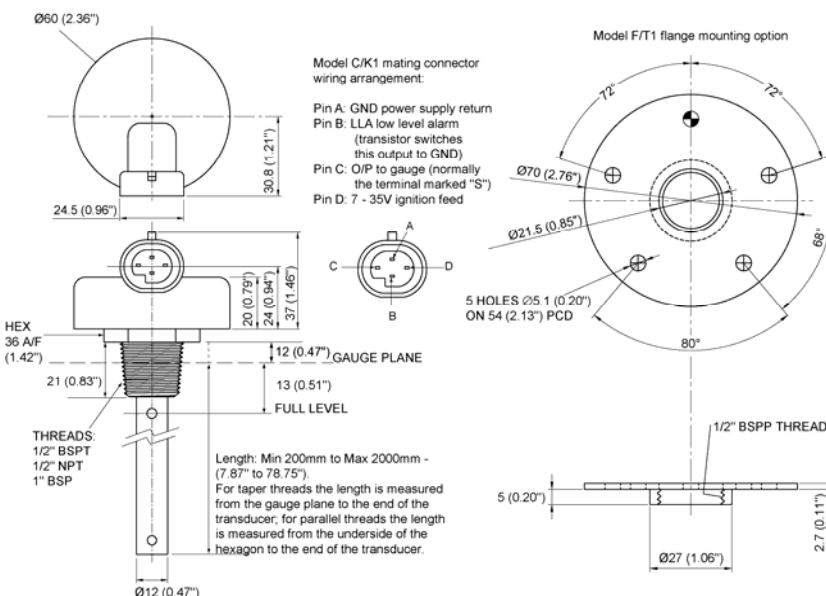

Model	Output	Manual Cal.
T/LL130	Resistive	No
T/LL131	Voltage	No
T/LL132	PWM	No
T/LL133	Resistive	Yes
T/LL134	Voltage	Yes
T/LL135	PWM	Yes

Berrington Road | Leamington Spa | Warwickshire CV31 1NB | UK

Tel: +44 (0)1926 466700 | Fax: +44 (0)1926 450473 | www.fozmula.com

www.fozmula.com

E. & O. E. © Fozmula Limited. July 2010 Issue No. 8

Since the suitability of these products depends upon a wide range of factors not in our control, Fozmula Limited expects and understands that you will conduct the testing and evaluation necessary to determine that these products are suitable for your application. Whilst every effort is made to ensure the above details are correct at the time of printing, Fozmula Limited reserves the right to make material changes, and or technical changes without notification.