

## TECHNICAL DATA

### G/LL28 liquid level contents gauge

**FOZMULA**  
INNOVATION IN SENSORS



The **G/LL28 Series** is a simple, robust, mechanical liquid level contents gauge using a float to move the dial pointer via a magnetic coupling. This prevents ingress of the tank contents into the indicator capsule.

The gauge is supplied with a Nitrile rubber gasket which ensures proper sealing when installed from the tank top or side.

The gauge fits a 6 hole flange, type G/MP2, and is supplied as standard with a 1 metre (optionally 0.5M) long float arm which may be cut to suit a specific tank depth by the customer.

## SPECIFICATION

### Mounting styles:

**Top mounting:** 90° float arm sweep 270° scale (non-linear)  
**Side mounting:** 90° float arm sweep 270° scale (linear)

### Construction:

**Flange:** Aluminium - Nickel plated  
**Main body:** Polyamide  
**Gear mechanism:** POM  
**Dial capsule:** Polycarbonate  
**Float arm:** Stainless steel  
**Float:** HDPE  
**Gasket:** Nitrile rubber

### Environmental:

**Compatibility:** Fluids compatible with materials of construction (Includes water, coolants, fuels etc.)

**Operating temperature:** -20°C to +80°C  
G/LL28 has been vibration tested to BS EN 60068-2-64:1993 (15.3grms).

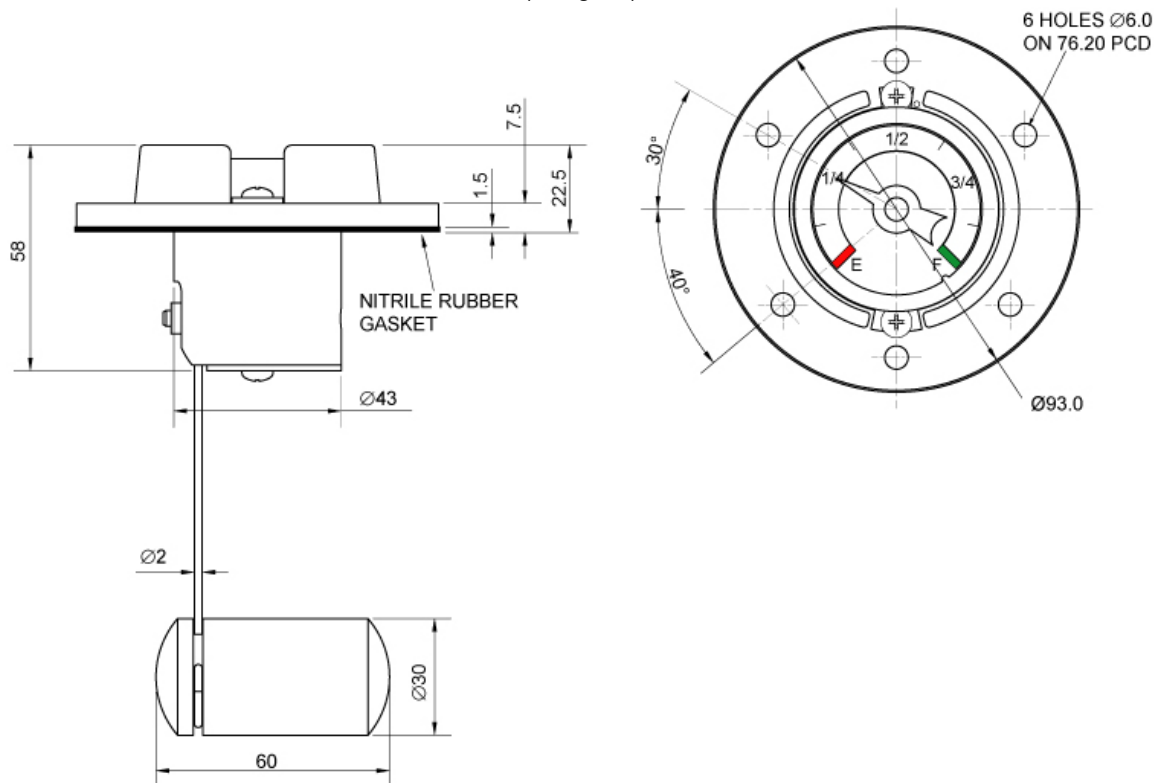

Berrington Road | Leamington Spa | Warwickshire CV31 1NB | UK

Tel: +44 (0)1926 466700 | Fax: +44 (0)1926 450473 | www.fozmula.com

[www.fozmula.com](http://www.fozmula.com)

E. & O. E. © Fozmula Limited. August 2008 Issue No. 4

Since the suitability of these products depends upon a wide range of factors not in our control, Fozmula Limited expects and understands that you will conduct the testing and evaluation necessary to determine that these products are suitable for your application. Whilst every effort is made to ensure the above details are correct at the time of printing, Fozmula Limited reserves the right to make material changes, and or technical changes without notification.